

# Modular meters

## ST100



Three-phase modular meter for residential consumers with plug-in communication and switching modules



ST100 is a three-phase modular meter designed for direct connection to grid and measurement of energy consumption of residential consumers. ST100 can also be implemented in single-phase networks. AMI system integration is enabled by connecting optional

plug-in communication module (CMxyS - PLC or GPRS/3G) and switching module (SD30S) via M-Bus connection. Both plug-in modules are simply mounted under the terminal cover. ST100 is compliant with all relevant standards and regulations.

### Key features

- Measurement of electrical values
- Integrated Real-time clock with DST
- Flexible tariff policy with up to 4 tariffs
- Maximum demand
- RS485 port
- Optical port
- DLMS/COSEM
- Fraud detection
- No-power reading and parametrization
- Billing profile / profiles
- Load profiles
- Power limit
- Code red
- Event logs
- Measurement of energy quality
- Firmware update
- Functional inputs/outputs
- Data security

**Measurements**

- Measurement of power and energy in both directions and absolute values (A+, A-, |A|), R+ and R- optionally.
- Active energy measurement – Index classes 1 and 2, reactive energy measurement (optional) - Class 2 or 3
- Measurement of voltages and currents by phases, frequency and power factor

**Maximum demand**

- Programmable maximum demand integration period is generated by internal clock (typically 1, 5, 10, 15, 30 or 60 minutes)

**Multi-rate registration and TOU**

- Programmable tariff structure (up to 4 tariffs)
- Up to 4 seasons and 4 weekly changeovers
- Up to 9 day types and 32 holidays
- Up to 10 daily changeovers

**Internal Real-time clock with DST**

- In accordance with IEC 62054-21
- Automatic DST switching (optional)
- Battery backup supply, optionally super-capacitor

**Visual communication with meter**

- LCD and display modes according to VDEW specifications
- Programmable selection of data and display sequence
- LED: 1000 imp/kWh / kvarh)
- 2 push buttons on the meter cover
- OBIS data ID code: IEC62056-61

**Optical port**

- Physical layer according to IEC 62056-21
- DLMS/COSEM communication protocol

**Electrical ports (physical layer)**

- Port A: RS 485 for communication with AMI Center (active)
- Port B: M-Bus master (for communication with the switching module and other energy meters) in accordance with EN 13757-2

**Inputs and outputs (optional)**

- 2 control inputs for tariff control
- 2 tariff outputs (100 mA)
- 2 pulse outputs
- 1 control output with bi-stable relay (5 A)

**Communication protocol**

- Optical port and port A: DLMS (IEC 62056-46)
- Port B: M-Bus (EN 13757-3)

**Billing profiles**

- Billing profiles (registered energy and maximum demand values by tariffs) are generated and stored for the last 18 billing intervals

**Load profiles**

- 4 load profiles with 7 channels each
- Independent, programmable registry intervals (5-60 minutes, 1-24 hours)
- Sufficient memory (4 320 registries, i.e. 15-minute average load profile (1 channel) is stored for 45 days

**Log books**

- Standard log book with up to 200 logs and states
- Energy quality log book
- Fraud detection log book
- Disconnector control log book

**Energy quality measurement**

- Maximum and minimum voltage registration
- Voltage variation registration
- Maximum current registration
- Outage registration (short outage – Event counter, long outage – Long power interruption log)
- Under-voltage and over-voltage measurement and registration in Quality Event log book

**Fraud detection**

- Detection of meter cover opening / closing
- Detection of terminal block cover opening / losing
- Detection of wrong authorization for meter parameterization
- Detection of strong magnetic field
- Detection of neutral conductor interruption
- Recording of events in the Fraud event log book

**Power limiting (optional)**

- Power or current limiting of electricity consumers by defining the limit value of power or current in the dedicated meter register
- Dedicated log book (10 switching module disconnections / connections)

**Code Red (optional)**

- Enables synchronous power limiting of groups (large number) of users in case of irregular situation on distribution network (e.g. lack of power)

**Firmware update**

- Enabled locally or remotely with no impact on accuracy, parameter configuration or billing data

**No-power reading**

- Local reading via display or optical port

**Integration into AMI system**

**Communication with AMI system**

- ST100 is ready for addition of plug-in communication module (PLC or GPRS/3G) on port A

**Load management**

- ST100 is ready for addition of plug-in switching device on port B
- Switching device in accordance with IEC 62055-31, UC2/UC3

**Data protection**

- Local parameterization is protected by multi-level passwords and push button positioned under terminal block cover

**Meter quality**

- High accuracy and long term stability of metering elements. No recalibration required during meter lifetime
- High meter reliability
- High immunity to EMC

**Current terminal block**

- For current up to 60 A: for all types of conductors up to 16 mm<sup>2</sup>
- For current up to 100 A: for all types of conductors up to 35 mm<sup>2</sup>

**Compact meter case**

- Dimensions and mounting points according to DIN 43857
- High quality, transparent, reinforced, self-extinguishing polycarbonate case
- IP54 protection against water and dust (in accordance with IEC 60529)

Accuracy class	
active energy	1 or 2
reactive energy	2 or 3
Nominal/maximum current	5 (60) A, 5 (120) A
Minimum current I <sub>min</sub>	0.05 I <sub>n</sub>
Nominal voltage, U <sub>n</sub>	3x230/400 V, 3x400 V, 230 V
Voltage range	0.8 U <sub>n</sub> – 1.15 U <sub>n</sub>
frequency	50 Hz
Ports	
optical port	IEC 62056-21 (physical layer) IEC 62056-46 (DLMS) comm. protocol
port A	RS485 IEC 62056-46 (DLMS) comm. protocol
port B	wired M-Bus master (EN 13757-2) EN 13757-3 comm. protocol
Comm. module (optional)	PLC, GPRS/3G
Switching module (optional)	3x230 V (3x90 A; 3x120 A), IEC 62055-31, UC2/UC3
Self-consumption	< 2 W
Insulation voltage	4 kV, 50 Hz, 1 min
Shock voltage	6 kV; 1.2 / 50 μs
Operational temperature range	-40 °C - +70 °C
Storage temperature range	-40 °C - +80 °C
IP protection	IP54, according to IEC 60529
Dimensions	273 x 177 x 91 mm
Weight	0.9 kg

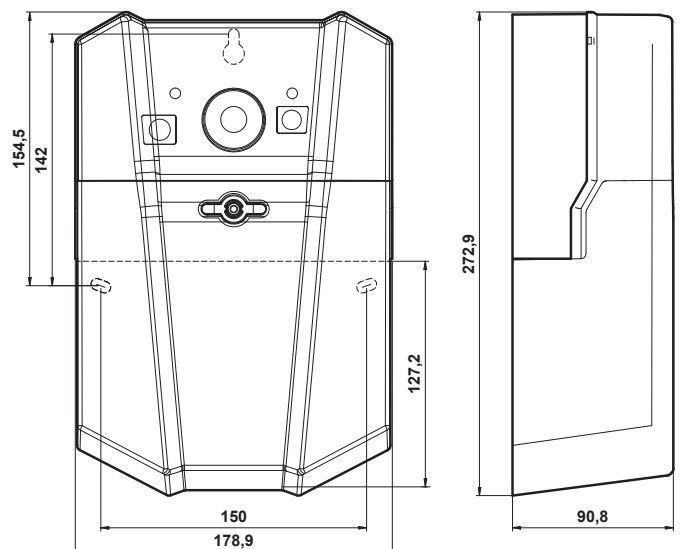

Meter&Control d.o.o. | Science Technology Park Belgrade  
 Veljka Dugoševića 54 | 11050 Belgrade | Serbia  
 office@meterandcontrol.com | www.meterandcontrol.com

*Solutions for smart energy management*