

## Smart meters

SM401 G3-PLC  
ST401 G3-PLC

Solutions for smart  
energy management



Integrated G3-PLC modem and  
switching device



IDIS<sup>2DLM</sup>  
Reg No: 0052



Sx401 G3-PLC are three-phase and single-phase smart meters designed for measurement of electrical energy of residential consumers, with integrated G3-PLC modem and switching module for remote reading and power management. Wide range of measurement values including power quality data in combination with large capacity of load profiles makes this meter a key tool for utilities for making insight in overall condition of low voltage network. Robust G3-PLC technology in

both CENELEC A and FCC frequency range, combined with IDIS Package 2 compatibility, makes this meter reliable and easy to integrate in existing utility environment. All functions are compliant with the following specifications and standards: IDIS, DLMS/COSEM, IEC 62052-11, IEC 62053-21/22/23, EN 50470-1/3 (MID), ITU G.9903/08-2017 (G3-PLC), and M-Bus.

### Key features

- Measurement of electrical values
- Integrated G3-PLC modem and switching device
- Internal real-time clock with DST
- Flexible tariff policy with up to 8 tariffs
- Maximum demand
- 230 V/50 Hz or 110 V/60 Hz supported
- Optical port
- Variety of additional input/output options available on demand (relays, pulse outputs, inputs e.a.)
- MID certificate
- DLMS/COSEM
- IDIS interoperability
- Fraud detection
- No-power reading and parameterization
- Billing profile
- Fraud profile
- Load profiles
- Measurement of energy quality
- Firmware update
- Functional inputs/outputs
- M-Bus port for G, W, H meters reading (Wireless M-Bus on demand)
- Support for in-home customer display
- High level data security



## Technical data

### SM401 G3-PLC ST401 G3-PLC

#### Measurements

- Measurement of power and energy in both directions and absolute values (A+, A-, |A|, R+, R-, R1, R2, R3, R4, S+, S- and by quadrants)
- Measurement of energies, voltages and currents per phase, network frequency and power factor

#### Maximum demand

- Programmable maximum demand integration period (typically 5, 10, 15, 30 or 60 minutes)

#### Multi-rate registration and TOU

- Programmable tariff structure (up to 8 tariffs)

#### Internal real-time clock with DST

- In accordance with IEC 62054-21
- Automatic DST (Daylight Saving Time) switching
- Backup battery supply (optionally super-capacitor)

#### Visual communication with meter

- Programmable selection of data and display sequence
- LED (1000 imp/kWh/kvarh)

#### Optical port

- Physical layer in accordance with IEC 62056-21
- Communication protocol - DLMS/COSEM

#### M-Bus micro master port

- Suitable for connection of gas, water or heat meters and in-home display
- Physical layer in accordance with EN 13757-2 (wired M-Bus), communication protocol EN 13757-2/3

#### Inputs and outputs

- Multiple configurations of 230 V, 5 A relays, low voltage and high voltage inputs/outputs for different functions, available according to customer specification
- Exact configuration is defined with customer according to specific order prior to manufacturing process

#### Communication options

- G3-PLC modulation in CENELEC A of FCC frequency range
- Speed up to 33600 bit/s
- Two-way, half-duplex channel

#### Optional RS485 port

- Allows local communication with meter, data reading and meter parameterization. Suitable for connection of up to 31 meters into single communication loop
- Half-duplex RS485 bus
- 9600 bit/sec communication speed

#### Integrated switching module (optional)

- Bi-stable switching module placed under meter cover for remote or local connection/disconnection
- Phase current break up to 100 A, whilst neutral stays closed
- In accordance with IEC 62055-31, UC3
- Minimum 10000 mechanical disconnections/reconnections under maximum load

#### Billing profiles

- Billing profile 1: recording billing data at the end of the programmable billing period with automatic reset of maximum demand. Programmable with up to 32 channels.

- Billing profile 2: recording billing data in case of fraud detection without reset of maximum demand

#### Load profiles

- 4 load profiles for measured values
- 4 M-Bus profiles for registration of measured data from other types of measuring devices (multi-utility)
- Programmable and independent registration periods (5, 10, 15, 30, 60 minutes and 24 hours)

#### Log books

- Standard log book
- Fraud detection log book
- Disconnect control log book
- Long power interruption log
- 4 M-Bus event logs which records events from other measuring devices which are connected to M-Bus port

#### Energy quality measurement

- In accordance with EN 50160
- Voltage variation registration
- Outage registration (short outage – Event counter, long outage – Long power interruption log)
- Under-voltage and over-voltage measurement and registration in Quality Event log book
- Voltage THD and Current THD registration

#### Fraud detection

- Detection of meter cover opening/closing
- Detection of terminal block cover opening/closing
- Detection of wrong authorization for meter parameterization
- Detection of strong magnetic field
- Detection of strong EMF
- Detection of neutral conductor interruption
- Recording of events in the Fraud event log book

#### Power limiting

- Power or current limiting of electrical consumers by defining the limit value of power or current in dedicated meter registers
- Programmable Tolerance time and Penalty time

#### Code Red

- Enables synchronous power limiting of groups (large number) of users in case of irregular situation on distribution network (e.g. lack of power)

#### Data security

- High level data security including authentication and data encryption

#### Firmware update

- Firmware is separated to Metrology and Applicative part according to Welmec 7.2, which allows safe update of applicative part of the firmware without need for additional meter verification after firmware update
- Firmware update can be done locally and remotely with no impact on accuracy, parameter configuration or billing data

#### No-power reading (optional)

- Local reading via display or via optical port in no power condition
- Integrated battery supply

#### Current terminal block

- For current up to 100 A
- For all types of conductors up to 35 mm<sup>2</sup>

#### Compact meter case

- Dimensions and fixing points in accordance with DIN 43857
- High quality, transparent, reinforced, self-extinguishing polycarbonate case
- IP54 protection against water and dust (in accordance with IEC 60529)

Accuracy Class	
Active energy	0,5S, 1 or 2 (C, B or A)
Reactive energy	2 or 3
Nominal and maximum current	5 (100) A
Nominal voltage, U <sub>n</sub>	110-230 V (single-phase) 3x(110-230)/(190-400) V (three-phase)
Voltage range	0.8 U <sub>n</sub> – 1.15 U <sub>n</sub>
Frequency	50/60 Hz
Optical port	IEC 62056-21 (physical layer) IEC 62056-46 (DLMS) communication protocol
Self-consumption	IEC 62053-21/22/23/61
Operational temperature range	-40 °C - +70 °C
Storage temperature range	-40 °C - +80 °C
Insulation AC strength	4 kV, 50 Hz, 1 min
Insulation impulse strength	6 kV; 1.2/50 μs
IP protection level	IP54, in accordance with IEC 60529
Dimensions	216 x 131 x 81 mm (single-phase) 302 x 178 x 81 mm (three-phase)
Weight	Approx. 0.83 kg (single-phase) Approx. 1.80 kg (three-phase)

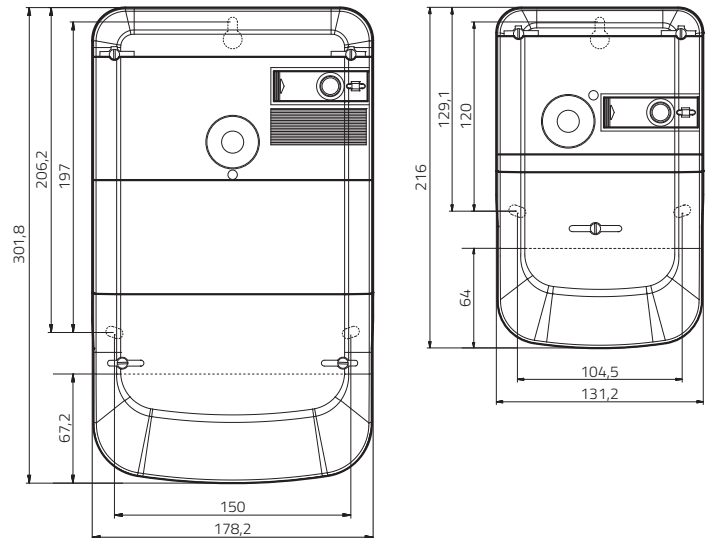

Meter&Control d.o.o.  
Science Technology Park Belgrade  
Veljka Dugoševića 54  
11050 Belgrade | Serbia

office@meterandcontrol.com  
www.meterandcontrol.com

Solutions for smart  
energy management

