

SM402D
Single-phase, direct connected meter with integrated cellular modem

ST402D
Three-phase direct connected meter with integrated cellular modem

ST402C
Three phase CT connected meter with integrated cellular modem



SM402 S are three-phase and single-phase smart meters designed for measurement of active and reactive electrical energy of residential, commercial and industrial consumers / prosumers with communication and switching modules. Wide range of measurement values including power quality data in combination with large capacity of load profiles makes this meter a key tool for utilities for getting insights in overall condition of power supply network. Integrated LTE modem with 3G/2G

backwards compatibility provides fast transmission of large volume of data to HES. Version with CAT M1 and NB IoT modem is also available. Variety of additional interfaces available as option makes this meter suitable for smart home system implementations at residential consumers as well as data collection hub in MV/LV substations (ST402C). Optional support for prepaid over cellular network makes this meter applicable in diverse DSO environments.

Key features

- Measurement of electrical values
- Integrated modem and switching device
- Internal real-time clock with DST
- Flexible tariff policy with up to 8 tariffs
- Maximum demand
- Optical port
- MID certificate
- DLMS/COSEM
- IDIS compliant
- Fraud detection
- No-power reading and parameterization
- Billing profile
- Fraud profile
- Load profiles
- Power limit
- Code red
- Event logs

- Measurement of energy quality
- Prepaid as option
- Firmware update
- Variety of optional inputs/outputs
- M-Bus port for G, W, H meters reading (Wireless M-Bus on demand)
- Support for in-home customer display
- High-level data security



Technical data

SM402 S ST402 S

Measurements

- Measurement of power and energy in both directions and absolute values (A+, A-, |A|, R+, R-, R1, R2, R3, R4, S+, S- and by quadrants)
- Measurement of energies, powers, voltages and currents per phase, network frequency and power factor

Maximum demand

- Programmable maximum demand integration period (typically 5, 10, 15, 30 or 60 minutes)

Multi-rate registration and TOU

- Programmable tariff structure (up to 8 tariffs)
- Up to 8 seasons, up to 8 weekly programs
- Up to 24 day types, up to 31 holidays
- Up to 48 tariff changes per day

Internal real-time clock with DST

- In accordance with IEC 62054-2.1
- Automatic DST (Daylight Saving Time) switching
- Backup battery supply (optionally super-capacitor)

Visual communication with meter

- Configurable LED constant
- Default (1000/10000) imp/kWh (kvarh) for direct/CT connected meters

Optical port

- Physical layer in accordance with IEC 62056-2.1

- Communication protocol - DLMS/COSEM mode C or mode E

M-Bus micro master port

- Suitable for connection of gas, water or heat meters and in-home display
- Physical layer in accordance with EN 13757-2 (wired M-Bus), communication protocol EN 13757-2/3

Inputs and outputs

- Multiple configurations of 230 V, 5 A relays, low voltage and high voltage inputs/outputs for different functions, available according to customer specification
- Exact configuration is defined with customer according to specific order prior to manufacturing process

Communication options

- Integrated cellular modem**
 - Cellular connection supported
 - Operating with static IP addresses
 - Frequency range: 800/900/1800/2100/2600 MHz
 - Replaceable SIM card
 - Antenna connector: SMA
 - Option of modem supporting NB IoT and CAT M1 operates on 700/800/900/1800 MHz.

Optional RS485 ports

- Allows local communication with meter, data reading and meter parameterization. Suitable for connection of up to 31 meters into single communication loop
- Half-duplex RS485 bus
- 9600 bit/sec communication speed
- Second RS485 port can be used for sending information towards in-home display

Integrated switching module (optional)

- Bi-stable switching module placed under meter cover for remote or local connection/disconnection
- Phase current break up to 100 A, whilst neutral stays closed
- In accordance with IEC 62055-31, UC3

- Minimum 10 000 mechanical disconnections/reconnections under maximum load

Billing profiles

- Billing profile 1: recording billing data at the end of the programmable billing period with automatic reset of maximum demand. Programmable with up to 32 channels
- Billing profile 2: recording billing data in case of fraud detection without reset of maximum demand

Load profiles

- 4 load profiles for measured values
- 4 M-Bus profiles for registration of measured data from other types of measuring devices (multi-utility)
- Programmable and independent registration periods (5, 10, 15, 30, 60 minutes and 24 hours)

Log books

- Standard log book
- Fraud detection log book
- Disconnect control log book
- Long power interruption log
- 4 M-Bus event logs which records events from other measuring devices which are connected to M-Bus port

Energy quality measurement

- In accordance with EN 50160
- Voltage variation registration
- Outage registration (short outage – Event counter, long outage – Long power interruption log)
- Under-voltage and over-voltage measurement and registration in Quality Event log book
- Voltage and current THD registration

Fraud detection

- Detection of meter cover opening/closing
- Detection of terminal block cover opening/closing
- Detection of wrong authorization for meter parameterization
- Detection of strong magnetic field
- Detection of strong EMF
- Detection of neutral conductor inter-

- ruption
- Recording of events in the Fraud event log book
- Optional switching module disconnection on fraud detection

Power limiting

- Power or current limiting of electrical consumers by defining the limit value of power or current in dedicated meter registers
- Programmable Tolerance time and Penalty time

Code Red

- Enables synchronous power limiting of groups (large number) of users in case of irregular situation on distribution network (e.g. lack of power)

Data security

- High level data security including authentication and data encryption

Firmware update

- Firmware is separated to Metrology and Applicative parts according to Welmec 7.2, which allows safe update of applicative part of the firmware without need for additional meter verification after firmware update
- Firmware update can be done locally and remotely with no impact on accuracy, parameter configuration or billing data

No-power reading (optional)

- Local reading via display or via optical port in no power condition
- Integrated battery supply

Current terminal block

- For current up to 100 A
- For all types of conductors up to 35 mm²

Compact meter case

- Dimensions and fixing points in accordance with DIN 43857
- High quality, transparent, reinforced, self-extinguishing polycarbonate case
- IP54 protection against water and dust (in accordance with IEC 60529)

Accuracy Class	
Active energy	0,5S, 1 or 2 (C, B or A)
Reactive energy	2 or 3
Nominal and maximum current	5 (100) A, 5 (6) A (for CT)
Nominal voltage, Un	110-230 V (single-phase) 3x(110-230)/(190-400) V (three-phase)
Voltage range	0.8 Un – 1.15 Un
Frequency	50/60 Hz
Optical port	IEC 62056-2.1 (physical layer) IEC 62056-46 (DLMS) communication protocol
Self-consumption	IEC 62053-2.1/2.2/2.3/6.1
Operational temperature range	-40 °C - +70 °C
Storage temperature range	-40 °C - +80 °C
Insulation AC strength	4 kV, 50 Hz, 1 min
Insulation impulse strength	6 kV; 1.2/50 µs
IP protection level	IP54, in accordance with IEC 60529
Dimensions	216 x 131 x 81 mm (single-phase) 302 x 178 x 81 mm (three-phase)
Weight	Approx. 0.83 kg (single-phase) Approx. 1.80 kg (three-phase)

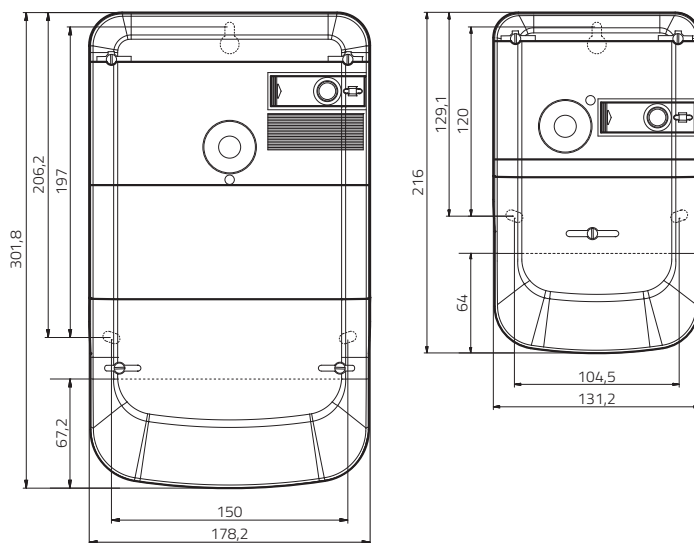

Meter&Control d.o.o.
Science Technology Park Belgrade
Veljka Dugoševića 54
11050 Belgrade | Serbia

office@meterandcontrol.com
www.meterandcontrol.com

Solutions for smart
energy management

